

Spare parts list for Low Pressure Spray Guns

Spray gun type: S = Stainless steel version

Ecco 40S, -401S, -402S

ECCO

ECCO FINISHING
ESL 12/01-04

Ecco 40S Pressure feed

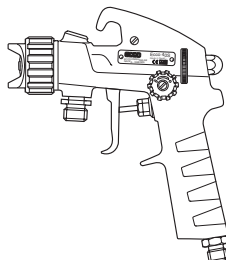

65130 F225-1

Pressure feed guns

Type of gun	Paint nozzle Orifice diam. mm	Air cap	Prod. No. With paint needle of nylon	Prod. No. With paint needle tip of tungsten-carbide
Ecco 40S	1.1	T274	8611 6013 60	
Ecco 40S	1.1	T278	8611 4040 11	
Ecco 40S	1.3	T272	8611 4040 13	
Ecco 40S	1.3	T274	8611 6013 63	
Ecco 40S	1.5	T274	8611 6013 62	
Ecco 40S	1.8 ^a	T272		8611 6023 59
Ecco 40S	1.8	T272	8611 4040 18	
Ecco 40S	2.1 ^a	T374	8611 6013 61	
Ecco 40S	2.7	T474	8611 4040 27	

^a Tungsten-carbide design

For further combinations, consult Ecco Finishing AB

Ecco 40S Suction feed

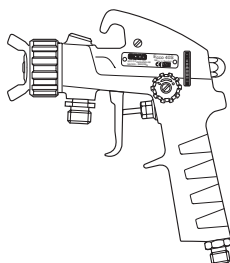

65130 F226-1

Suction feed guns

Type of gun	Paint nozzle Orifice diam. mm	Air cap	Prod. No. With paint needle of nylon	Prod. No With paint needle of stainless steel
Ecco 40S	1,3	273	8611 4000 13	
Ecco 40S	1.5	273	8611 4000 15	
Ecco 40S	1.8	271	8611 4000 18	
Ecco 40S	1.3	273		8611 4005 13
Ecco 40S	1.5	273		8611 4005 15
Ecco 40S	1.8	271		8611 4005 18

For further combinations, consult Ecco Finishing AB

Ecco 401S Suction feed with suction cup

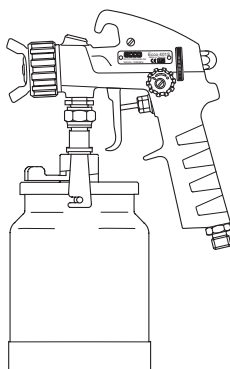

65130 F234-1

Suction feed guns with suction cup 1.0 lit.

Type of gun	Paint nozzle Orifice diam. mm	Air cap	Prod. No. With paint needle of nylon
Ecco 401S	1.2	170	8611 4010 12
Ecco 401S	1.5	273	8611 4010 15
Ecco 401S	1.8	271	8611 4010 18
Ecco 401S	1.8	275	8611 4010 38
Ecco 401S	1.8	375	8611 4010 21

For further combinations, consult Ecco Finishing AB

Ecco 402S Gravity feed

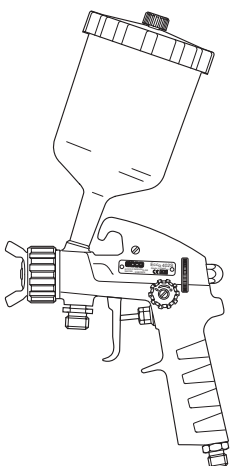

65130 F228-1

Gravity feed guns with gravity cup 0.5 lit.

Type of gun	Paint nozzle Orifice diam. mm	Air cap	Prod. No. With paint needle of nylon
Ecco 402S	1,2	170	8611 4020 12
Ecco 402S	1.3	273	8611 4020 13
Ecco 402S	1.5	275	8611 4020 35
Ecco 402S	1.8	271	8611 4020 18
Ecco 402S	1.8	275	8611 4020 38
Ecco 402S	2.1	375	8611 4020 21

For further combinations, consult Ecco Finishing AB

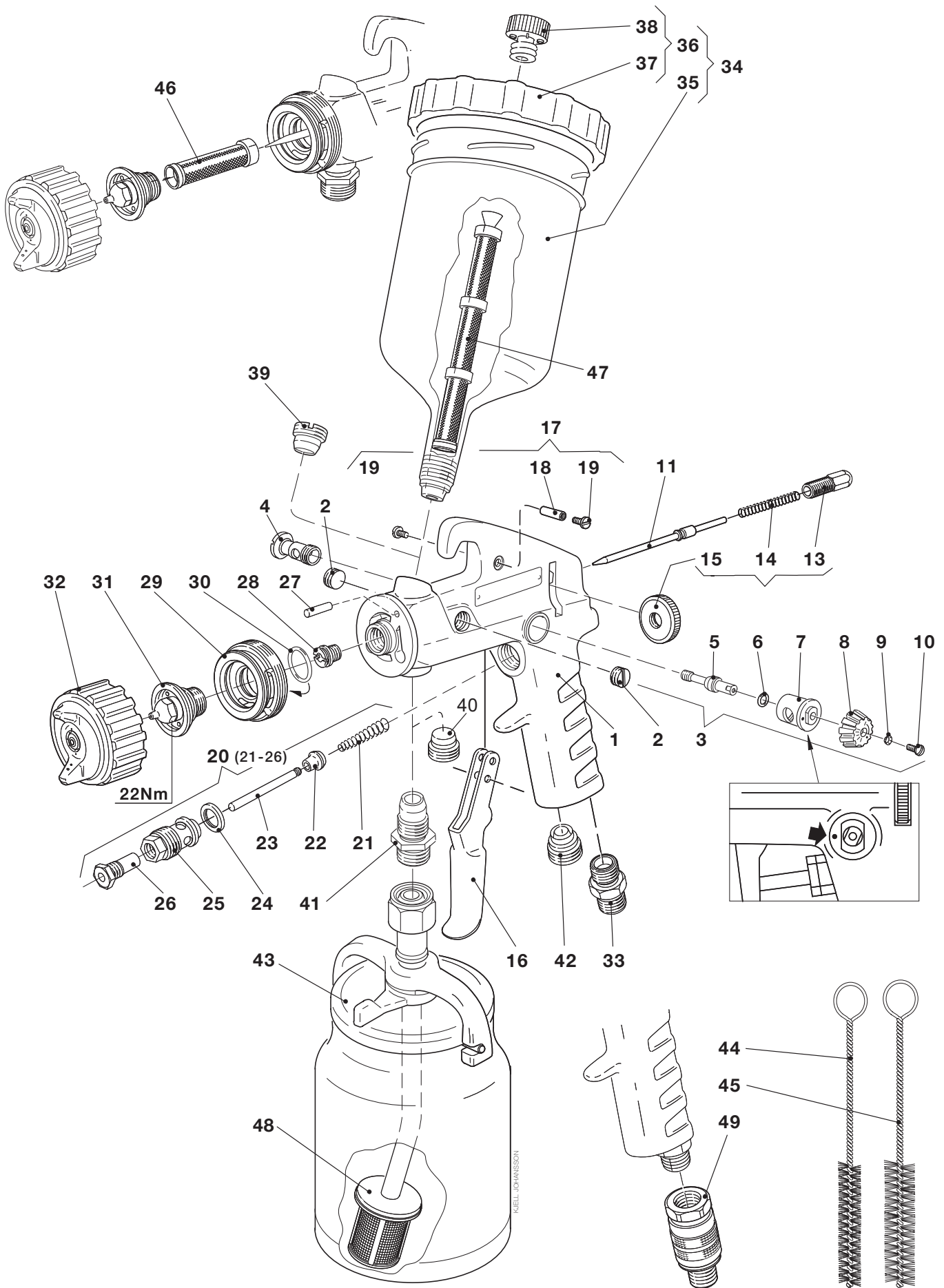

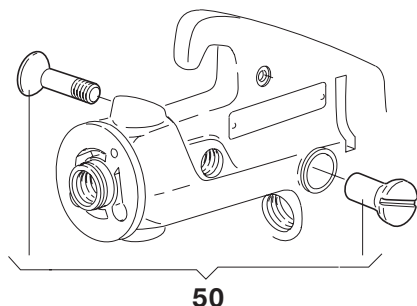

65130 F285

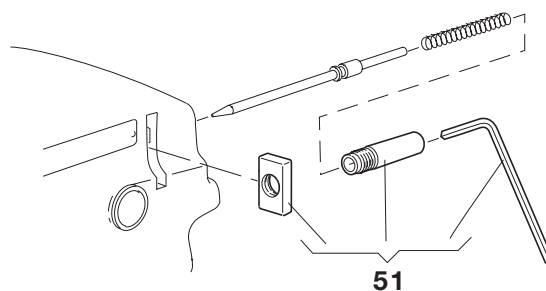

65130 F286

Service set 6003 9095 00 for Ecco 40S, -401S, -402S

Consists of parts with ref. Nos. 2 (Qty. 1), 6, 9, 10, 18, 19, 21, 22, 24, 26, 28 and 30.

Part numbers **in bold type** designate consumption parts.

Ref. No.	Part number	Qty			Description	Ref. No.	Part number	Qty			Description
		-40S	-401S	-402S				-40S	-401S	-402S	
1	6003 9229 00	1	1	1	Gun body	Optional Equipment					
2	6000 8369 00 ^g	2	2	2	Screw	-	6101 6065 00	1	1	1	Retaining ring, acetal plastic (for air cap)
3	6101 5100 00	1	1	1	Fan width control, compl.	3	6101 9230 00	1	1	1	Fan width control for left handed
4	6101 3788 00	1	1	1	- Valve screw	3	6003 9602 00	1	1	1	Quick fan width control
5	6101 3790 00	1	1	1	- Valve pin	14	6101 2582 65	1	1	1	Spring, soft (2.7 kg)
6	6101 3796 00 ^g	1	1	1	- O-ring	14	6001 2036 00	1	-	-	Spring, stiff (6.4 kg)
7	6101 3789 00	1	1	1	- Valve housing	29	6102 1215 00	1	1	1	Distribution ring, compl. (SS)
8	6101 3648 00	1	1	1	- Wheel	32	6000 1877 00	1	1	1	Air inlet nipple (9/16" 20G)
9	0164 5013 00 ^g	1	1	1	- Lock washer (V 3.2)	33	6002 0233 00	1	1	1	Air inlet nipple (1/4" 18 NPSM)
10	0333 5109 00 ^g	1	1	1	- Screw (MKFS 3 x 6 SS A2)	34	6101 5560 95	-	-	1	Paint cup Ecco G 1.25, volume 0.125 l
11	(see page 4)	1	1	1	Paint needle	41	6102 9314 46	1	-	-	Paint inlet nipple (G 1/4 SS)
12	6000 9191 80	1	1	1	Back head, compl.	41	6003 7393 00	1	-	-	Paint inlet nipple (9/16" 20G SS)
13	6000 9191 00	1	1	1	- Back head	43	6003 9676 00	-	1	-	Suction cup Ecco SD 15T, volume 1 l (inside coated with teflon)
14	6101 2582 00	1	1	1	- Spring (3.4 kg)	46	6103 3200 00^c	1	1	1	Strainer set ^d 60 mesh (white)
15	6000 7764 00	1	1	1	- Wheel	46	6103 3201 00^c	1	1	1	Strainer set ^d 100 mesh (yellow)
16	6101 2796 00	1	1	1	Trigger (SS)	46	6103 3202 00^c	1	1	1	Strainer set ^d 200 mesh (black)
17	6101 2990 80	1	1	1	Shaft, compl.	46	6103 1088 00^c	1	1	1	Strainer ^e 300 mesh (red)
18	6101 2990 00 ^g	1	1	1	- Shaft (SS)	47	6003 9754 05	-	-	1	Strainer set ^f 60 mesh (white)
19	0164 5013 91 ^g	2	2	2	- Screw (MSCS A4-70 3 x 6 SS)	47	6003 9752 05	-	-	1	Strainer set ^f 100 mesh (yellow)
20	6101 5730 00	1	1	1	Air valve, compl.	48	6003 7886 00	-	1	-	Strainer set ^d 80 mesh
21	6101 2111 00 ^g	1	1	1	- Spring	49	6003 8002 00	1	1	1	Throttle valve (G1/4)
22	6101 5008 00 ^g	1	1	1	- Air valve	50	6101 5247 80	1	1	1	Plug set, for gun is not fitted with fan width control
23	6101 3631 00	1	1	1	- Valve pin	51	6102 1203 80	1	1	1	Back head, lockable fluid volume control
24	6001 1008 00 ^g	1	1	1	- Packing						
25	6003 2167 00	1	1	1	- Valve housing						
26	6101 5716 00 ^g	1	1	1	- Bushing						
27	0101 4131 00 ^b	1	1	1	Pin (CP 4h6 x 10 SS)						
28	6103 3131 00 ^g	1	1	1	Packing screw (SS/HD500)						
29	6102 1214 00	1	1	1	Distribution ring with O-ring						
30	6101 1724 00 ^g	1	1	1	- O-ring						
31	(see page 4)	1	1	1	Paint nozzle						
32	(see page 4)	1	1	1	Air cap						
33	6001 2619 00 ^a	1	1	1	Nipple (G 1/4)						
34	6101 5560 00	-	-	1	Paint cup Ecco G 5, compl.						
35	6101 5561 00	-	-	1	- Paint cup, volume 0.5 l (G 3/8)						
36	6101 5559 00	-	-	1	- Cover, compl.						
37	6003 9094 00	-	-	1	-- Cover						
38	6003 9068 00	-	-	1	-- Plug (Drip guard)						
39	6003 9974 00	1	1	-	Plug (G 3/8)						
40	6101 3742 00	-	-	1	Plug (M14 x1)						
41	6101 5021 00	1	1	-	Nipple (G 3/8 SS)						
42	6101 5626 00	1	1	1	Plug (G 3/8)						
43	6003 9714 00	-	1	-	Suction cup Ecco SD 15, volume 1 l (see spare parts list No. 9836 3175, ESL 12/04-20)						
44	6000 8004 00	1	1	1	Cleaning brush (ø10 mm)						
45	6000 8001 00	1	1	1	Cleaning brush (ø17 mm)						
46	(see optional equipment)	3	3	-	Strainer 100 mesh						
47	(see optional equipment)	-	-	1	Strainer 100 mesh						

^aLocktite 225. ^bLocktite 243. ^cNot for plastic paint nozzle. ^dSet of 10. ^eSold singly. ^fSet of 5. ^gIncluding in service set.

Nozzle sets

Consists of air cap, paint nozzle of stainless steel and paint needle of nylon.

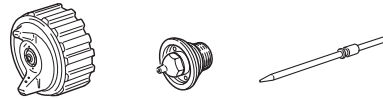

Pressure feed					Suction and Gravity feed				
Paint nozzle Orifice diam. mm	Type	Paint needle Type	Air cap Type	Nozzle set Part number	Paint nozzle Orifice diam. mm	Type	Paint needle Type	Air cap Type	Nozzle set Part number
1.1	1.1	P007	T278	6003 9772 11	1.1	1.1	P007	271	6003 9771 11
1.3	1.3	P07	T272	6003 9772 13	1.3	1.3	P07	273	6003 9771 13
1.5	1.5	P07	T272	6003 9772 15	1.5	1.5	P07	273	6003 9771 15
1.8	1.8	P07	T272	6003 9772 18	1.8	1.8	P07	271	6003 9771 18
2.1	2.1	P07	T374	6003 9772 21	2.1	2.1	P07	375	6003 9771 21
2.7	2.7	P07	T474	6003 9772 27	2.7	2.7	P07	475	6003 9771 27

Nozzle combinations

Paint nozzle (a) (b)			Paint needle (a) (b)		Air cap (b) (c) (d)			Air consumption l/min at 4 bar
Orifice diam. mm	Designation	Part number	Designation	Part number	Designation	Part number		
0.8	0.8	6001 0241 00			170	6101 2588 00	215	
0.8	B0.8	6001 0966 00	007 P007	6001 0548 00 6101 5747 00	270	6101 2589 00	285	
					271	6101 5249 00	380	
					273	6103 3159 00	370	
					275	6101 2590 00	380	
					T272	6101 2599 00	480	
1.1	1.1	6001 1068 00	P1107 ^e	6101 5616	T272 ^f	6101 2599 00	480	
					T272 ^f	6102 3992 00	480	
					T278	6101 5614 00	480	
					T278 ^f	6102 3991 00	480	
1.2	1.2 P1.2	6001 0276 00 6001 1476 00	07 P07	6000 9275 00 6001 1471 00 6000 9881 00	170	6101 2588 00	215	
					271	6101 5249 00	380	
1.3	1.3 P1.3 H1.3	6001 0999 00 6001 1477 00 6001 1092 00	P1307 ^e	6101 5982 00	273	6103 3159 00	370	
					T272	6101 2599 00	480	
					T272 ^f	6102 3992 00	480	
					T274	6101 2602 00	480	
					PT274	6101 5785 00	480	
					T278	6101 5614 00	480	
					T278 ^f	6102 3991 00	480	
1.5	1.5	6103 1303 00	07 P07 H07	6000 9275 00 6001 1471 00 6000 9881 00	270	6101 2589 00	285	
					271	6101 5249 00	380	
					273	6103 3159 00	370	
					T272	6101 2599 00	480	
1.8	1.8 P1.8 H1.8	6000 9140 00 6001 1478 00 6001 0768 00	P1807 ^e 1807 ^e	6101 3844 00 6101 3848 80	M270	6101 3293 00	155	
					270	6101 2589 00	285	
					271	6101 5249 00	380	
					273	6103 3159 00	370	
					275	6101 2590 00	380	
					T274	6101 2602 00	480	
2.1	2.1 P2.1 H2.1	6000 9141 00 6001 1479 00 6000 9876 00	P2107 ^e	6003 9366 00	M370	6101 3294 00	265	
					375	6101 2591 00	385	
					T374	6101 2603 00	510	
2.7	2.7 H2.7	6000 9142 00 6000 9877 00	07 P07	6000 9275 00 6001 1471 00 6000 9881 00	M470	6101 3295 00	305	
					475	6101 2592 00	385	
					T474	6101 2604 00	510	
3.7	3.7	6000 9287 00	57 P57	6000 9289 00 6101 6056 00	M570	6101 3296 00	500	
					T576	6101 2607 00	540	
6.5	6.5	6001 0451 00	67	6001 0453 00	T676	6101 2608 00	585	

^a The letter "H" before the designation denotes tungsten-carbide design.

^b The letter "P" before the designation denotes nylon design. The rear part of the nylon needle is made of steel.

^c Air caps for round spray with "M" in the designation should be used together with stop ring 6101 3298 00.

^d Air caps with a "T" in the designation are designed for pressure feed only. The other air caps are designed for suction feed but can also be used for pressure feed.

^e Fluid needle with cylindrical point.

^f Acetal plastic retaining ring.

Operator's Instructions

- Use Ecco genuine parts and accessories only for best function and safety.
- Before starting, read through all instructions carefully.

Principal data

Type	Max. working pressure bar	Paint cup volume l
Ecco		
40S	7	-
401S	7	1
402S	7	0.5



WARNING

The high velocity flow of air and liquids through hoses and nozzles may develop static electricity. Be sure that the equipment, object being sprayed, spraybooth, paint and waste container are properly grounded to prevent static discharge or sparks.

Important



WARNING

Do not use halogenated hydrocarbons in coating application equipment where aluminium or galvanized parts come in contact with the solvent or coating material. Halogenated hydrocarbons e.g. 1,1,1-trichloroethane and methylene chloride react, violently with such parts, causing corrosion and danger for explosion.



WARNING

As the equipment works under pressure the utmost care must be observed during the work. Bearing this in mind, never aim the spray gun at a person or towards any part of the body. In the event of personal injury caused by the spraying pressure, immediate medical attention is essential. Before carrying out any adjustment or repair, the equipment must be switched off and the paint pressure relieved.



Paint spraying



CAUTION

Inhalation of paint, paint dust and solvent is not healthy. Make sure an approved spraybooth is used. The operator must use personal protection-breathing mask or fresh air hood.

Disassembly-Reassembly (see Fig. page 1) (see also Fig. 2)



WARNING

Before any intervention on the spray gun, shot off and relieved the compressed air supply and paint pressure to the gun.

Operation

- Install and operate the spray gun according to Fig. 1.
- Blow the paint and air hoses clean before connection.
- Check that all connections are tight (pay particular attention to the connection between paint cup and spray gun).
- Keep the spray gun clean and lubricate moving parts at regular intervals.
- Lubricants for surface-treatment equipment must **not** contain silicon.
- For short standstill periods, for instance over a night, it will suffice to clean the air and paint nozzles on the outside. If a two-component paint is used, however, the gun **must be flushed through immediately** with solvent. This must also be done if the gun is to remain unused for a longer period of time.
- When cleaning the air cap and the paint nozzle, use a soft brush or rag dipped in solvent. Do not place the entire gun in solvent, as the oil on the lubricated parts would be dissolved. Blow the air cap dry with compressed air from both sides.
- Never use iron or steel wire to clean air holes and ducts in the nozzles.

Connections and controls (see Fig. 1)

- 3 Fan width adjusting. If the knob is screwed all the way in a round fan will be obtained other positions give broad fans.
- 15 Paint flow adjusting. Clockwise turning result in a smaller paint flow and counter-clockwise turning increases the flow. The fluid flow is regulated in the first instance by the choice of paint nozzle and paint pressure.
- 33 Atomizing air hose connection G 1/4.
Hose: Inside dia. 6.3 mm (1/4").
- 41 Paint hose connection G 3/8.
Hose: Inside dia. 6.3 mm (1/4") or 9.5 mm (3/8").

How to operate

Recommended paint viscosity differs according to paint properties and painting conditions. 15 to 23 sec./Ford cup 4 is recommendable.

The gun is operate at low air pressure, high transfer efficiency will not be obtained if the spray distance is to far.

Set the spray distance from the gun to the work piece as near as possible within the range of 150-300 mm.

Air caps

The air caps are tested and certified according to the SEAVA method. This gives a "finger print" of the spray pattern on each air cap. For further information please contact your supplier.

The retaining ring for the air cap shall only be tightened with hand force. No tools are required. Especially important when a capcleaner is used.

Air caps can be sent back for checking and comparity the performance. For further interesting please contact your supplier.

Before reassembling the different components:

- Clean the parts with the appropriate cleaning agent by means of brush.
- Install new seals after having lubricated them with PTFE grease.
- Install new parts if necessary.

Needle packing and needle

1. Remove the air cap (32), and the paint nozzle (31).
2. Unscrew the back head (13) by screwing the wheel (15) counter-clockwise.
3. Remove the spring (14) and the paint needle (11).
4. Dismantle the packing screw (28).
5. Clean everything well with cleaning agent and then blow out with air.
6. Assembly the packing screw (28) ont he paint needle (11).
7. Re-fit the paint nozzle (31) (screwing torque 22 Nm), squeeze the trigger (16) to avoid damaging the tip of the paint needle, and refit the air cap (32) by hand.

Distributor ring

1. Dismantle the distributor ring (29) by screwing on the air cap (32) a few turns. Withdraw the distributor ring axially from the gun body.
2. Assembly the distributor ring (29) by mating it with a pin (27) in the gun body.

Fan width control

Check when fitting the valve housing (7) that the marking on the body agrees with fig. below.

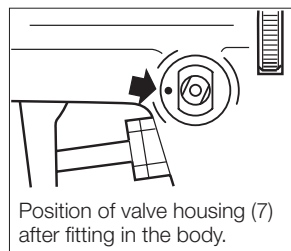

65130 F302

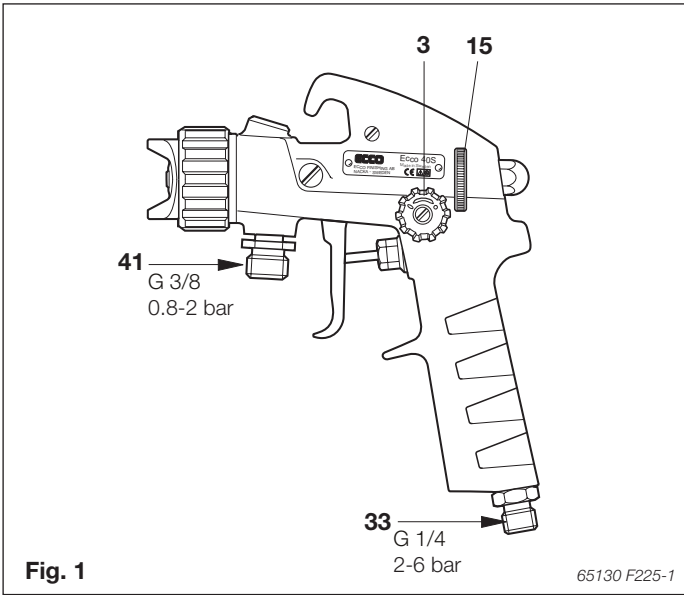

Fig. 1

65130 F225-1

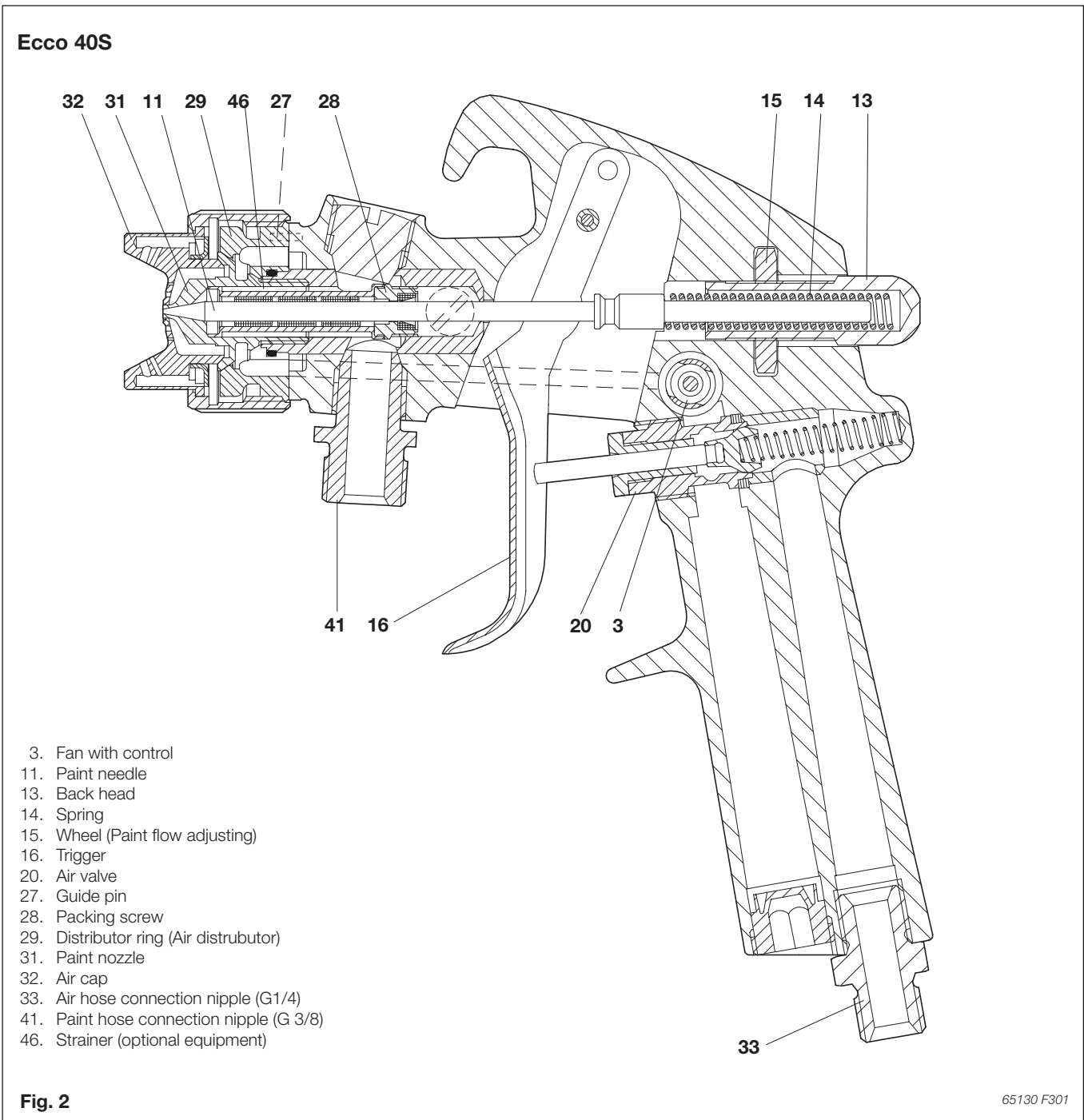

Fig. 2

65130 F301

Troubleshooting

Introduction

Always commence troubleshooting by checking the general condition of the spray gun. This can most easily be determined by test spraying, which provides an opportunity for checking the spray pattern and capacity, air leakage and gasket leakage.

Types of problems

Collection of information which makes it possible to identify the error symptoms applicable to the spray gun in the event of malfunctioning is a matter of vital importance. Identification of symptoms makes it possible to decide whether the spray gun itself is the direct cause of the malfunctioning or if this may have been caused by an external factor.

The following external factors can cause malfunctioning and should be thoroughly checked:

1. The quality of the air, i.e. content of moisture, dirt particles and oil.
2. The quality of the paint, i.e. its viscosity, purity, etc.
3. The air and paint pressure in relation to viscosity of the paint and nozzle combination used.
4. The size of the air/paint hoses.

Troubleshooting chart



Correct Spray Pattern

Spray Pattern	Cause	Remedy
<p>Asymmetrical to the left or to the right</p>	<ol style="list-style-type: none"> a) Dried paint on holes for atomizing air. b) Damage to holes for atomizing air. c) Air cap not sufficiently tightened. 	<ol style="list-style-type: none"> a) Dried paint on holes for atomizing air. Clean the air holes, use appropriate cleaning agent and a soft brush. b) Damage to holes for atomizing air. Replace the air cap with a new one. c) Air cap not sufficiently tightened. Tighten the air cap properly by hand.
<p>Distorted in the middle</p>	<ol style="list-style-type: none"> a) Damage to the tip of the paint nozzle. b) The pressure of the atomizing air in relation to the viscosity of the paint. 	<ol style="list-style-type: none"> a) Fit a new paint nozzle. b) Adjust the air pressure of the atomizing air.
<p>Narrowing off in the middle</p>	<ol style="list-style-type: none"> a) Wrong nozzle combination. b) Fan air pressure too high. c) Paint viscosity unsuitable. d) Incorrect spray angle. 	<ol style="list-style-type: none"> a) Select a new nozzle combination suitable for the viscosity of paint. b) Reduce the pressure of the fan air. c) Adjust the viscosity of the paint. d) Adjust the angle with the fan width control.
<p>Irregular spray (spitting)</p>	<ol style="list-style-type: none"> a) Paint needle gasket leaky. b) Damaged O-ring in distributor ring. c) Paint nozzle not tightened. d) Dirt on sealing surfaces of paint nozzle and distributor ring. e) Paint hose connection not tightened. f) Paint hose defective. 	<ol style="list-style-type: none"> a) Change the packing screw. b) Change the O-ring in the distributor ring. c) Tighten the paint nozzle. d) Clean the sealing surfaces of the paint nozzle and distributor ring with solvent and blow clean. e) Tighten the paint hose connection. f) Change the paint hose.

Paint leaking - Air leaking	Cause	Remedy
Paint leaking	Worn packing screw and/or needle.	Replace damaged parts with new ones.
Paint leaking through the paint nozzle when the gun is closed.	Pollution between the needle and the nozzle or needle and nozzle worn or damaged.	Unscrew air cap (32) and nozzle (31). Clean carefully and check for any sign of damages or wear.